



Staple type: N50 Staples
Wire Ø: 0.89mm

Suitable for the following tools:

Paslode 1000 N-50SR

Staple lengths available: 6mm – 19mm
Staples per strip: 100

CORROSION PROTECTION

Finish	Usage Environment	Label Colour on Packaging
Zinc Galv 1-3µm	INDOOR 	Blue

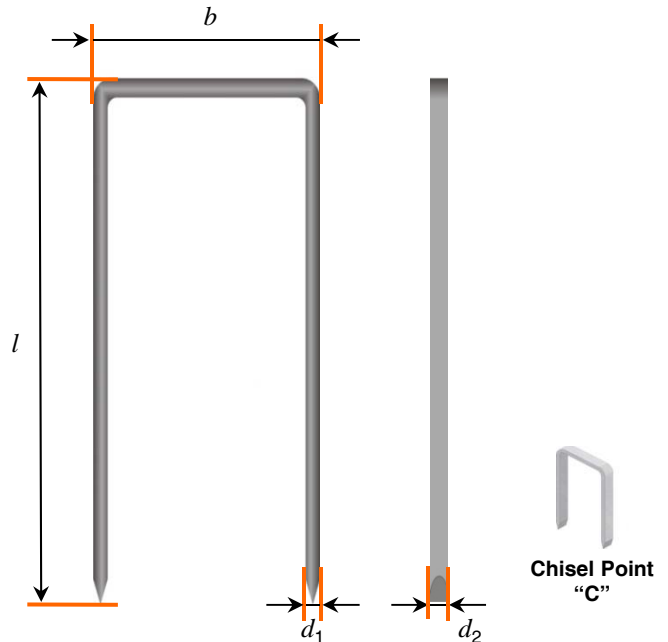

STAPLE PROPERTIES / DIMENSIONS

Tensile strength of wire:	min 900 N/mm ²
Nominal diameter (<i>d</i>):	0.89mm
Flattened wire dimension:	(<i>d</i> ₁): 0.58mm (<i>d</i> ₂): 1.12mm
Outside crown width (<i>b</i>):	5.15mm
Strip length:	approx 112.50mm
Standard point:	“C”
Coated leg length:	Full

STAPLE LENGTHS AVAILABLE*

Finish	Lengths Available <small>*Other lengths on request</small>
Zinc Galv 1-3µm	6mm, 10mm, 12mm, 16mm, 19mm

Paslode is a brand of the ITW Group. ITW reserves the right to change specification without notice. All design using this data should be carried out by a qualified structural engineer, subject to relevant National and European standards or regulations.