



Staple type: N30 Staples
Wire Ø: 0.68mm

Suitable for the following tools:

Paslode 1000 N-30SR

Staple lengths available: 10mm – 12mm
Staples per strip: 156

CORROSION PROTECTION

Finish	Usage Environment	Label Colour on Packaging
Stainless Steel A2 AISI 304 / WNr 1.4301	INDOOR, COVERED OUTDOOR & OUTDOOR	Yellow

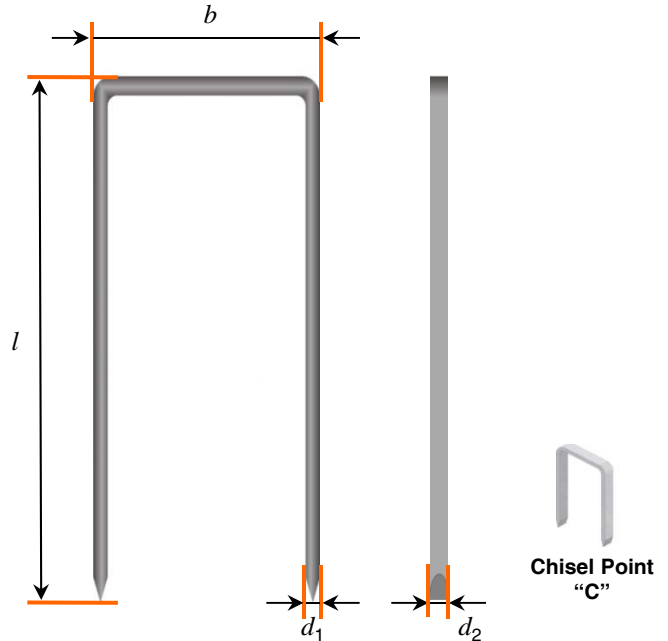

STAPLE PROPERTIES / DIMENSIONS

Tensile strength of wire:	min 900 N/mm ²
Nominal diameter (<i>d</i>):	0.68mm
Flattened wire dimension:	(<i>d</i> ₁): 0.55mm (<i>d</i> ₂): 0.77mm
Outside crown width (<i>b</i>):	5.20mm
Strip length:	approx 128.00mm
Standard point:	“C”

STAPLE LENGTHS AVAILABLE*

Finish	Lengths Available *Other lengths on request
Stainless Steel A2 AISI 304 / WNr 1.4301	10mm, 12mm

Paslode is a brand of the ITW Group. ITW reserves the right to change specification without notice. All design using this data should be carried out by a qualified structural engineer, subject to relevant National and European standards or regulations.