





Staple type: KL 500
 18 GAUGE STAPLES MEDIUM CROWN
 Wire Ø: 1.15mm

Suitable for the following tools*:

haubold PN 530 L-1 / Automatik LM
 PN 540 (L-1)
 PN 530 / 540 V
 PN 540 A
 Toolmatic S330.3701
**please check staple length compatibility with each tool before use*
 Staple lengths available: 10mm – 40mm
 Staples per strip: 100 - 104

CORROSION PROTECTION

Finish	Usage Environment	Label Colour on Packaging
Zinc Galv	INDOOR 	Blue
Stainless Steel A2 AISI 304 / WNr 1.4301	INDOOR, COVERED OUTDOOR & OUTDOOR 	Yellow

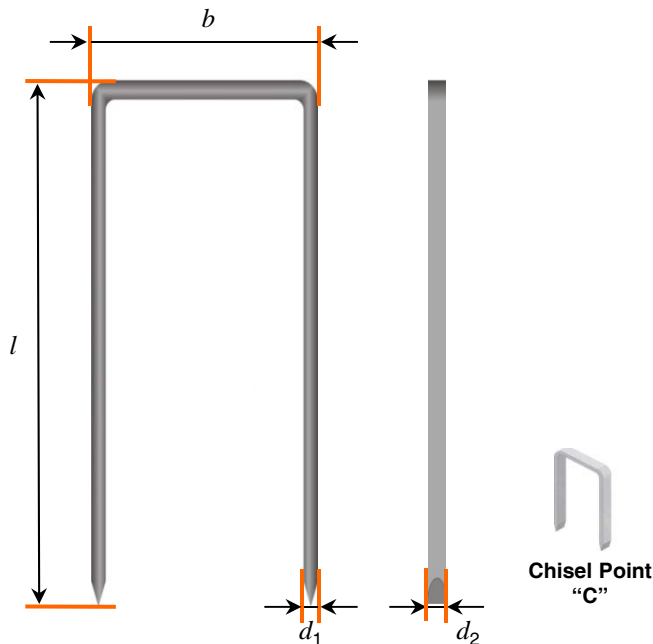

STAPLE PROPERTIES / DIMENSIONS

Tensile strength of wire: min 900 N/mm²
 Nominal diameter (d): 1.15mm
 Flattened wire dimension: (d₁): 1.00mm
 (d₂): 1.23mm
 Outside crown width (b): 11.00mm
 Strip length: approx 128.00mm
 Standard point: "C" & "D"
 Coated leg length: Full

STAPLE LENGTHS AVAILABLE*

Finish	Lengths Available <small>*Other lengths on request</small>
Zinc Galv	'C' Point: 10mm, 12mm, 14mm, 15mm, 20mm, 22mm, 25mm 'D' Point: 24mm, 30mm
Stainless Steel A2 AISI 304 / WNr 1.4301	30mm, 40mm

haubold is a brand of the ITW Group. ITW reserves the right to change specification without notice. All design using this data should be carried out by a qualified structural engineer, subject to relevant National and European standards or regulations.