





Staple type: 50 Series Staples
Wire Ø: 0.89mm

Suitable for the following tools*:

Duo-Fast LDS-5016
CS-5000
HT-550C
Toolmatic S230.3203 / S230.3204
**please check staple length compatibility with each tool before use*

Staple lengths available: 4mm – 16mm
Staples per strip: 84

CORROSION PROTECTION

Finish	Usage Environment	Label Colour on Packaging
Zinc Galv 1-3µm	INDOOR 	Blue
Stainless Steel A2 AISI 304 / WNr 1.4301	INDOOR, COVERED OUTDOOR & OUTDOOR 	Yellow

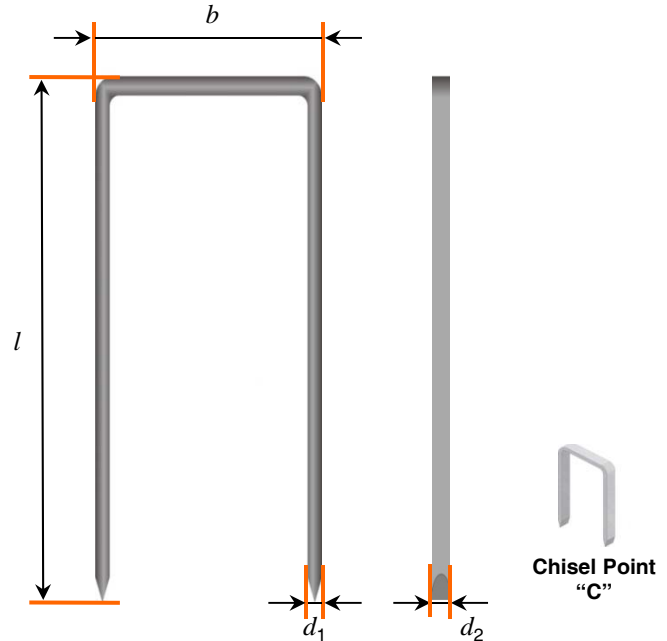

STAPLE PROPERTIES / DIMENSIONS

Tensile strength of wire: min 900 N/mm²
Nominal diameter (*d*): 0.89mm
Flattened wire dimension: (*d*₁): 0.50mm
*d*₂): 1.25mm
Outside crown width (*b*): 12.50mm
Strip length: approx 105.50mm
Standard point: "C"
Coated leg length: Full

STAPLE LENGTHS AVAILABLE*

Finish	Lengths Available <small>*Other lengths on request</small>
Zinc Galv 1-3µm	4mm, 6mm, 8mm, 10mm, 12mm, 14mm, 16mm
Stainless Steel A2 AISI 304 / WNr 1.4301	6mm, 8mm, 10mm, 14mm

Duo-Fast is a brand of the ITW Group. ITW reserves the right to change specification without notice. All design using this data should be carried out by a qualified structural engineer, subject to relevant National and European standards or regulations.